

Wire and drill holes before installation.

1. The wire on the motor is very short, the customer needs to buy their own wire to make the motor wire longer (the length of the wire depends on the position of the motor box).

So Please bring your own wire and power cord and plug.

2. Position of the control box.

The control box can be placed anywhere on the post or where the customer wants it to be placed.

The control box is placed on the post, and it is necessary to drill two holes in the post to hide the line in the post.

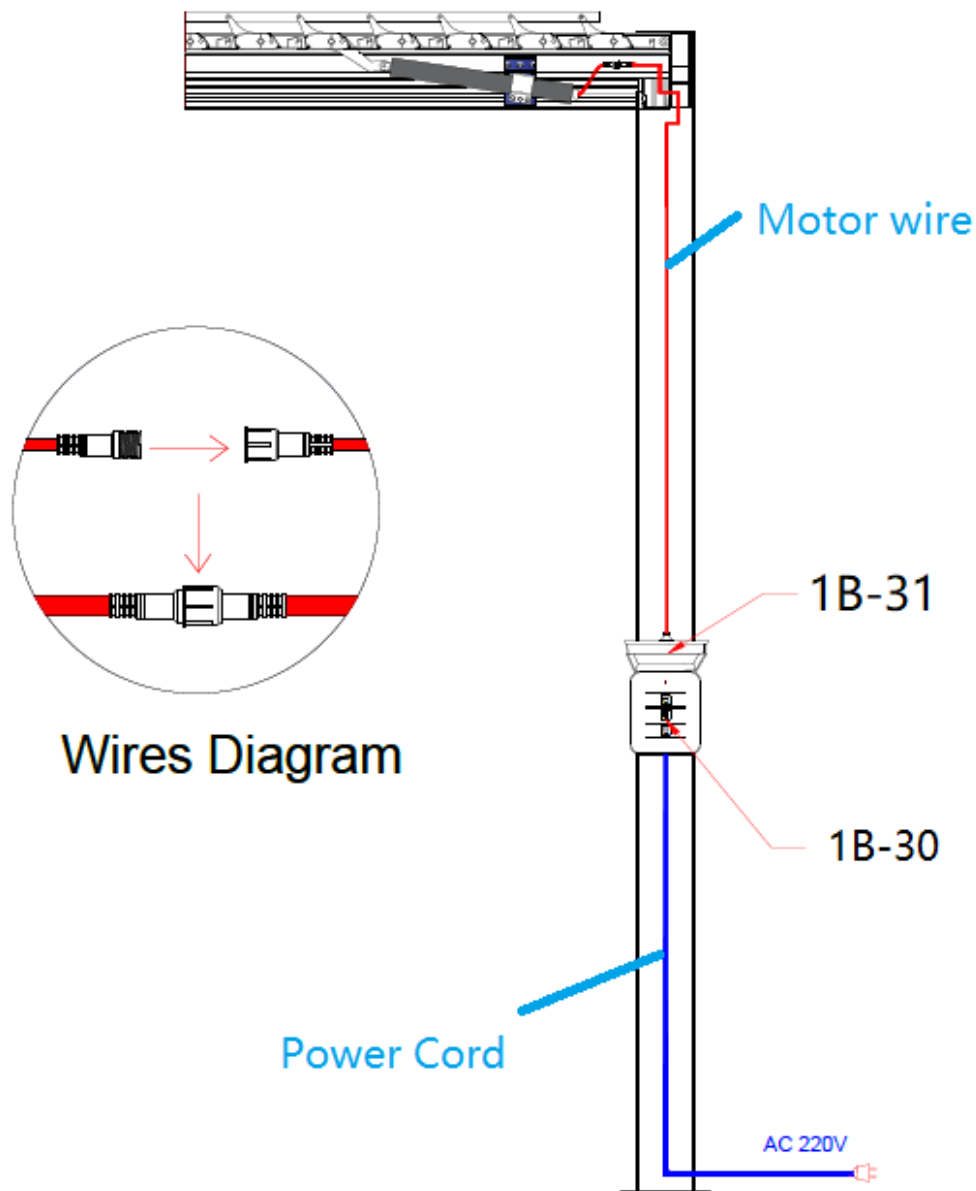

2 holes as following

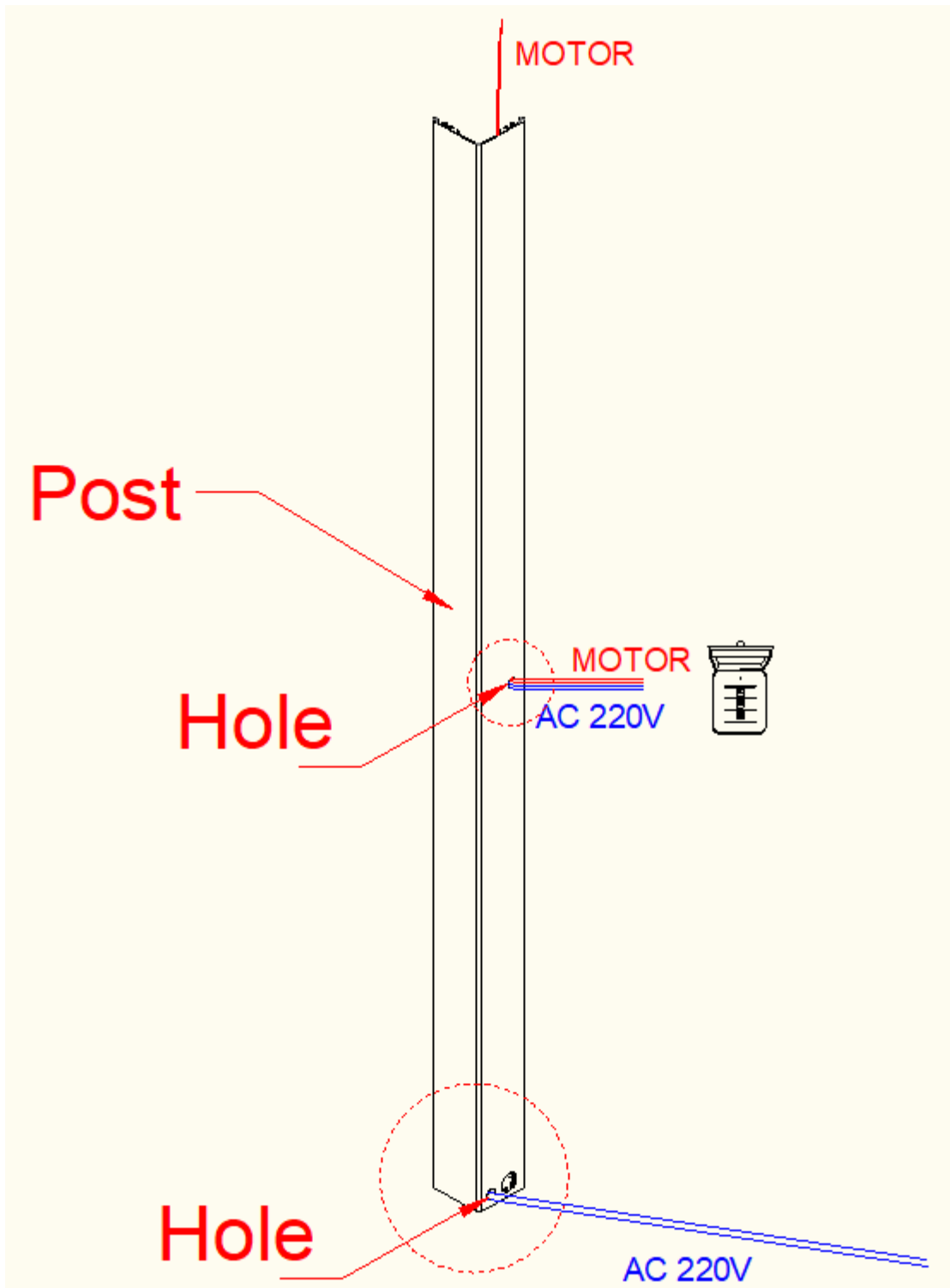

Not on the post, a location the customer wants. Just drill a hole in the post, as shown in the image below

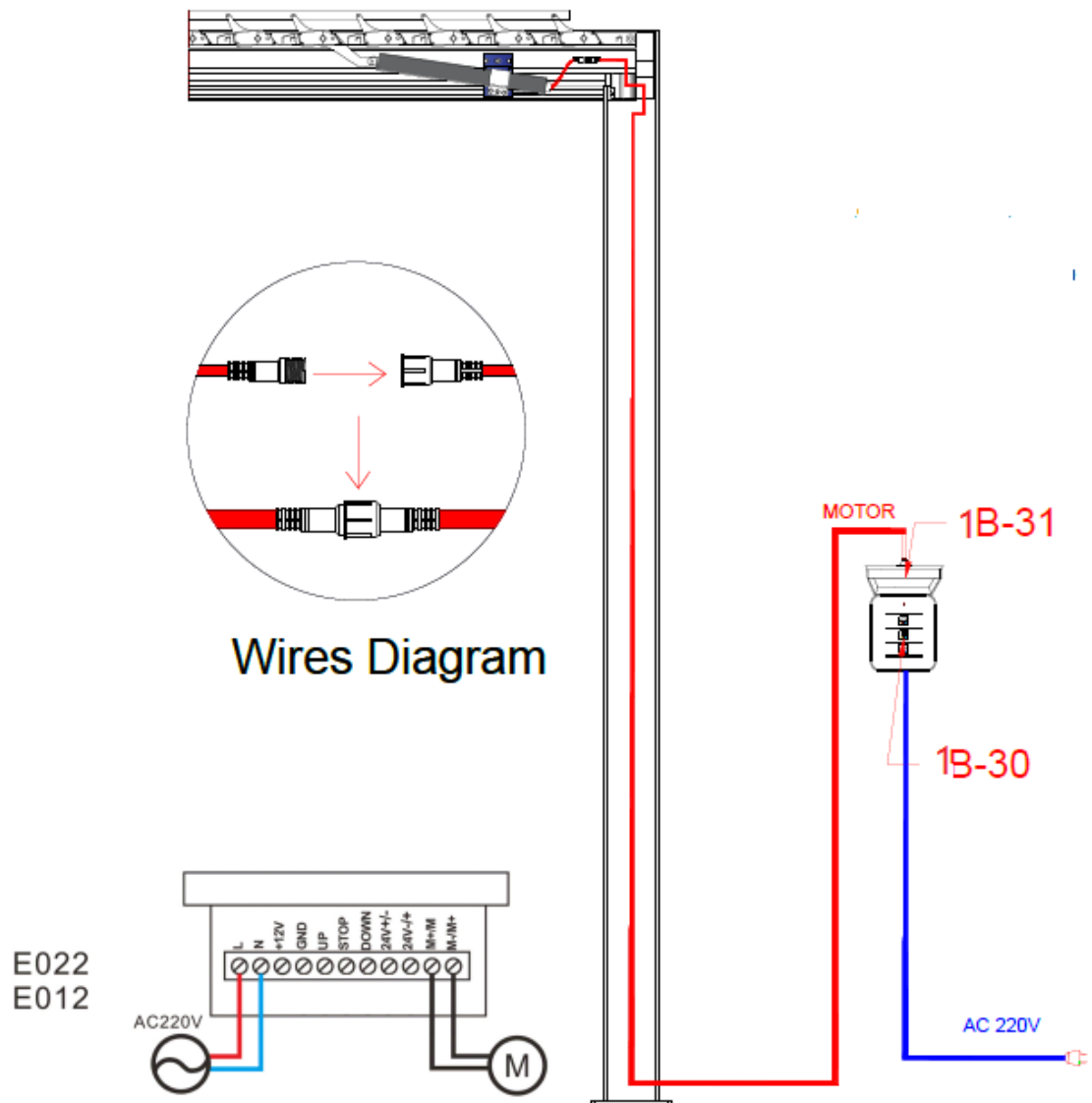

3. The control box is fitted with mounting screws